



6 GHz SMA N/O S.P.4 T. Subminiature SWITCH

OPTIONS :

R F CHARACTERISTICS

NUMBER OF WAYS : 4
 FREQUENCY RANGE : 0 - 6 GHz
 IMPEDANCE : 50 Ohms

FREQUENCY (GHz)	0 - 3	3 - 6
V.S.W.R <=	1.20	1.30
INSERT. LOSS <=	0.20 dB	0.30 dB
ISOLATION >=	80 dB	70 dB
AVER.POWER (25°C)	240 W	170 W

ELECTRICAL CHARACTERISTICS

ACTUATOR : NORMALLY OPEN
 NOMINAL CURRENT AT 25°C (±10%) : 110 mA
 ACTUATOR VOLTAGE (Vcc) : 28V (21 to 30V) / NEGATIVE COMMON
 TERMINALS : 16 pin double row connector for connecting to 2.54mm pitch female socket wrapping or soldering (250°C max/30 sec)

MECHANICAL CHARACTERISTICS

CONNECTORS : SMA female per MIL C 39012
 LIFE : 10.000.000 cycles per position
 SWITCHING TIME (nominal voltage;25°C) : < 10 ms
 WEIGHT : < 120 g

ENVIRONMENTAL CHARACTERISTICS

OPERATING TEMPERATURE RANGE (°C) : -40 , +85
 STORAGE TEMPERATURE RANGE (°C) : -55 , +85
 VIBRATION - MIL STD 202, meth.204 : 10 - 2000Hz , 20g (operating)
 SHOCKS - MIL STD 202, meth.213 : 100 g / 6ms / half-sine (operating)

This information is given as an indication. In the continual goal to improve our products, we reserve the right to make any modifications judged necessary

4112-9212

4113-9212 This information is given as an indication. In the continual goal to improve our products, we reserve the right to make any modifications judged necessary

R591.303.400

DRAWING

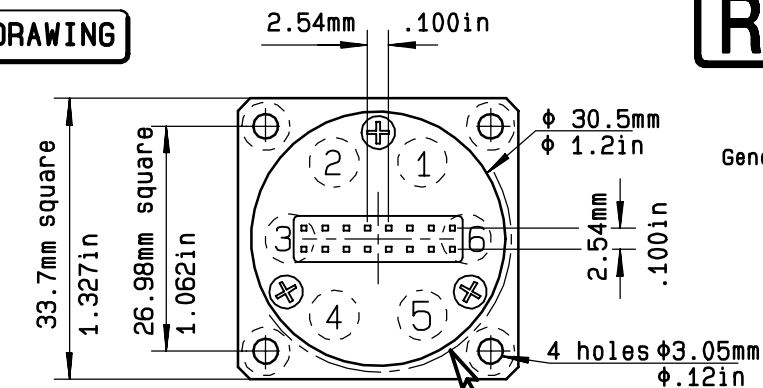

General tolerance: ± 0,5 mm

Voltage	RF continuity
-C +1	IN ↔ 1
-C +2	IN ↔ 2
-C +3	IN ↔ 3
-C +4	IN ↔ 4

16 pin double row connector MARKING

0.64mm (.025in) SQ.

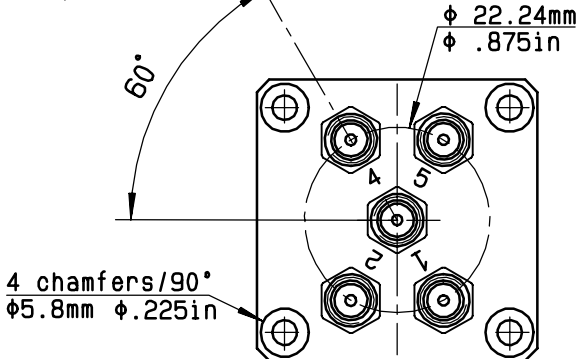
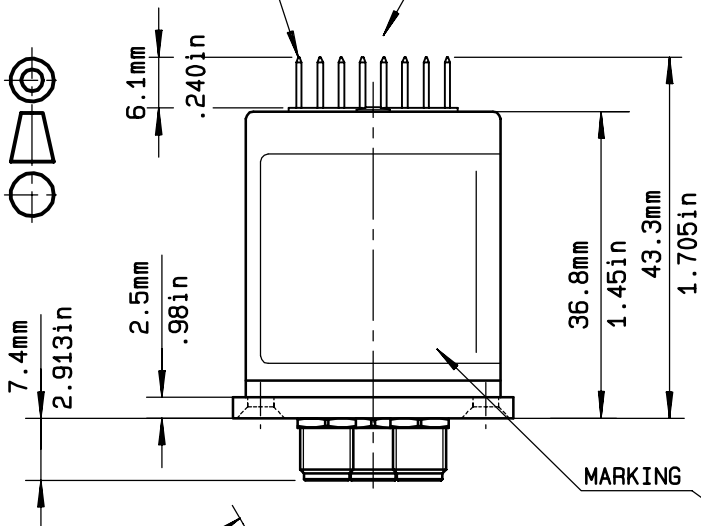

MARKING

TOP VIEW (TERMINALS)

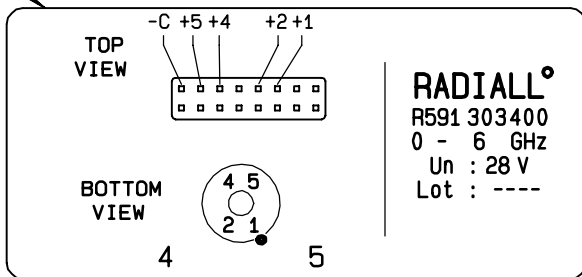

SCHEMATIC DIAGRAM

